

To find out how we use your information, please see our [privacy notice](#).

Your ref no:
ZWDZXSXS

Details of the Business and Applicant

Business name*

The Frog on the Bine

Applicant name*

Position (if applicable) (optional)

Director

Address of Business* (for the pavement licence)

Building name (optional)

Building number (optional)

9

Street

Cavendish Circus

Town / Village

Buxton

Postcode

SK17 6AT

Applicant Telephone (daytime/office)

Applicant Telephone (emergency out of hours)

Email address

Name and address of Owner (if different to applicant) (optional)

W

*These details will be included in a public notice on the premises and the local authority website

To find out how we use your information, please see our [privacy notice](#).

Your ref no:
ZWDZXSKS

Details

Part of the Highway to which the application relates

Pavement in front of the premises

Purpose or purposes for which the furniture will be used (to sell or serve food or drink or consumption of food or drink)

For the consumption of drink bought on the premises

Details of the days of the week and the hours between which the furniture will be used

Monday - Time from (not before 9am) (optional)

1200

Monday - Time to (no later than 11pm) (optional)

2300

Tuesday - Time from (not before 9am) (optional)

1200

Tuesday - Time to (no later than 11pm) (optional)

2300

Wednesday - Time from (not before 9am) (optional)

1200

Wednesday - Time to (no later than 11pm) (optional)

2300

Thursday - Time from (not before 9am) (optional)

1200

Thursday - Time to (no later than 11pm) (optional)

2300

Friday - Time from (not before 9am) (optional)

1200

Friday - Time to (no later than 11pm) (optional)

2300

Saturday - Time from (not before 9am) (optional)

1200

Saturday - Time to (no later than 11pm) (optional)

2300

Sunday - Time from (not before 9am) (optional)

1200

Sunday - Time to (no later than 11pm) (optional)

2300

To find out how we use your information, please see our [privacy notice](#).

Your ref no:
ZWDZXSXS

Type of Furniture to which the application relates

Details of proposed furniture

Applicants are required to describe the type of furniture (including approximate sizes)

Modern, Bistro style furniture of wood & metal construction

Proposed Number of tables (including approximate sizes)

Three tables approximately 55cm x 55cm

Proposed number of chairs (including approximate sizes)

Twelve chairs approximately 40cm x 40cm

To find out how we use your information, please see our [privacy notice](#).

Your ref no:
ZWDZXSXS

Uploads

Please upload the following:

A sketch diagram / plan of the area that will be included in the licence showing proposed layout of tables, chairs and the surrounding barriers (*Please include the dimensions of the area and the distance in Metres from the edge of the barrier to the kerbside*)

Upload File(s)

IMG_20250326_082306.jpg

A copy of your **Public Liability Insurance** indicating that the sum insured is **no less than £5,000,000**

Upload File(s)

The
Frog
on
the
Bine
Ltd.pdf

A copy of the Public Consultation Notice that is to be displayed at the premises to which this application applies

Upload File(s)

HPBC_2024_Notice_Template_Guidance_Notes.docx

Photographs of the furniture that you intend to provide

Upload File(s)

Furniture.docx

Please ensure that all 4 documents above have been uploaded, failure to do so will result in a delay in your application.

To find out how we use your information, please see our [privacy notice](#).

Your ref no:
ZWDZXSKS

Conditions, Declaration and Indemnity

Public Consultation

I undertake to carry out the necessary public consultation in accordance with the requirements of the Act and note that if found to have failed to comply with these requirements the licence will be void and no compensation will be payable

Agree

Indemnity

In the event of the Local Authority granting permission sought herein, I agree to indemnify and hold harmless the relevant Council(s) from and against all actions in law or inequity, damages, statutory or common law losses, costs charges and expenses arising in manner whatsoever out of the placing of tables, chairs and other items on pavements

Agree

Conditions of Pavement Licence

I have read, understood and give my undertaking to observe and abide by the conditions of the licence and any other additional conditions, which may be listed as part of this licence supplied to me

Agree

Right to revoke or Suspend Pavement Licence

I understand that the Local Authority has the right to revoke or suspend the licence and that no compensation will be payable

Agree

I confirm that a clear pedestrian route along the highway can be maintained at all times compliant with the current social distancing requirements and current social mobility requirements for pushchairs and wheelchair/mobility scooter users, which is no less than 2m wide and where there is high pedestrian footfall shall be no less than 2.5m. This distance is measured from the furthest edge of the barrier to the nearest kerbside

Agree

Are you a charity or not for profit organisation

Yes

No

Pavement licence

£100.00

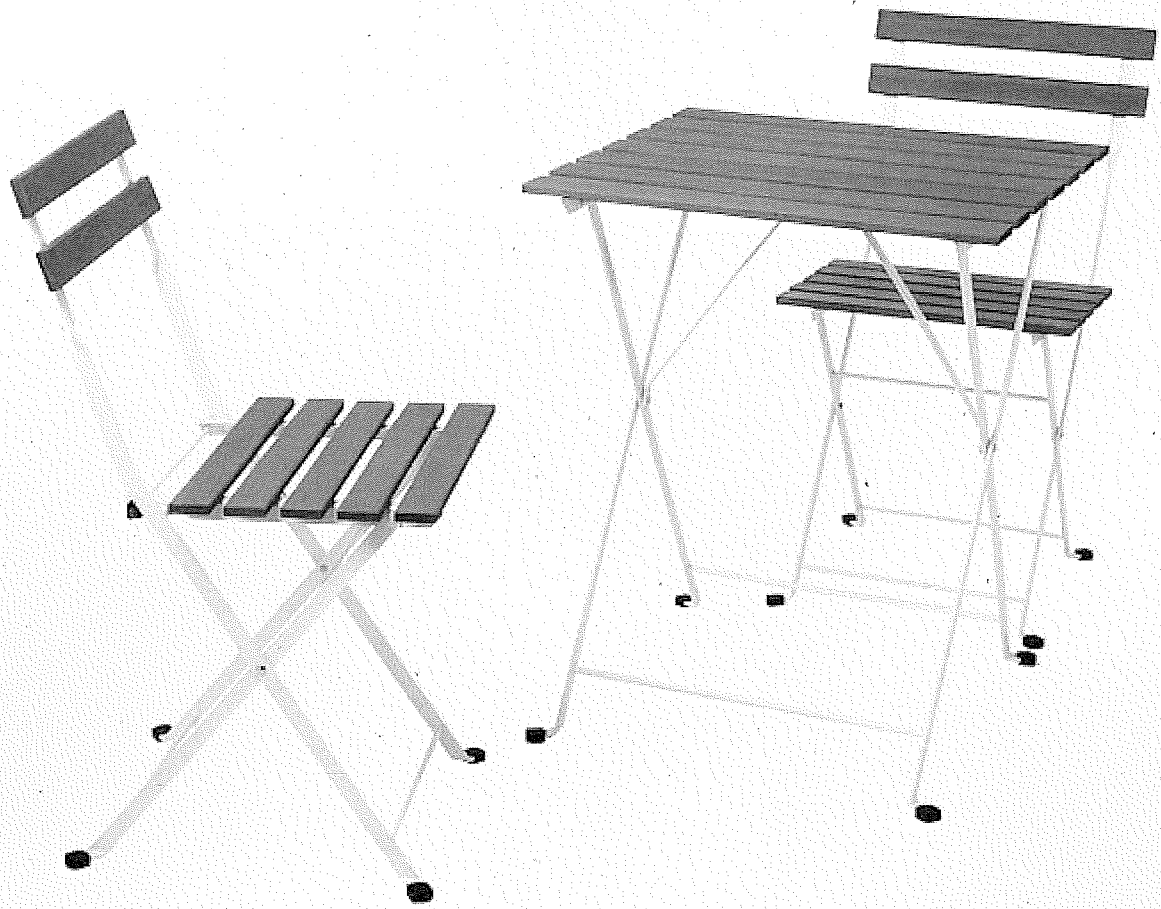

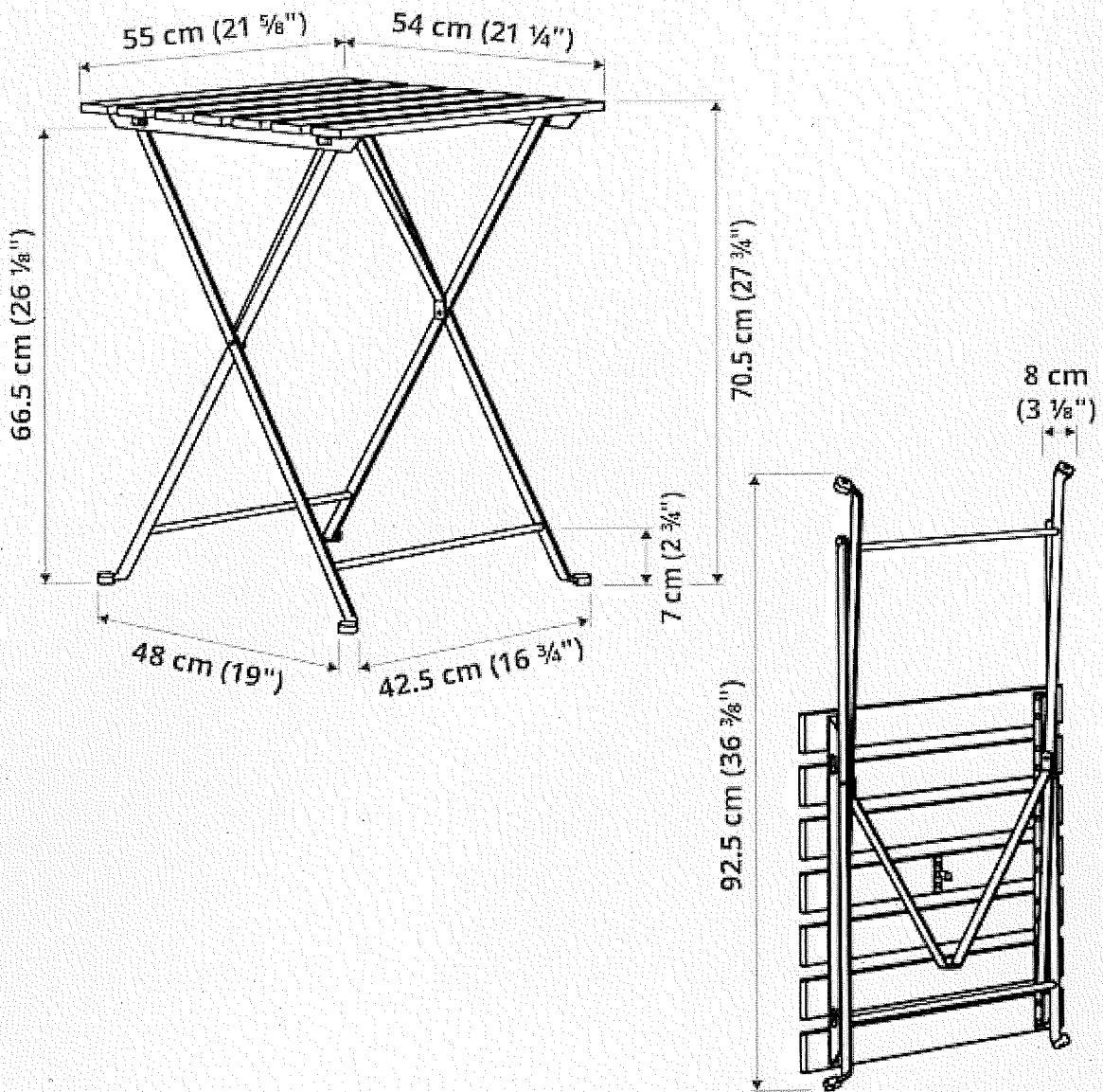

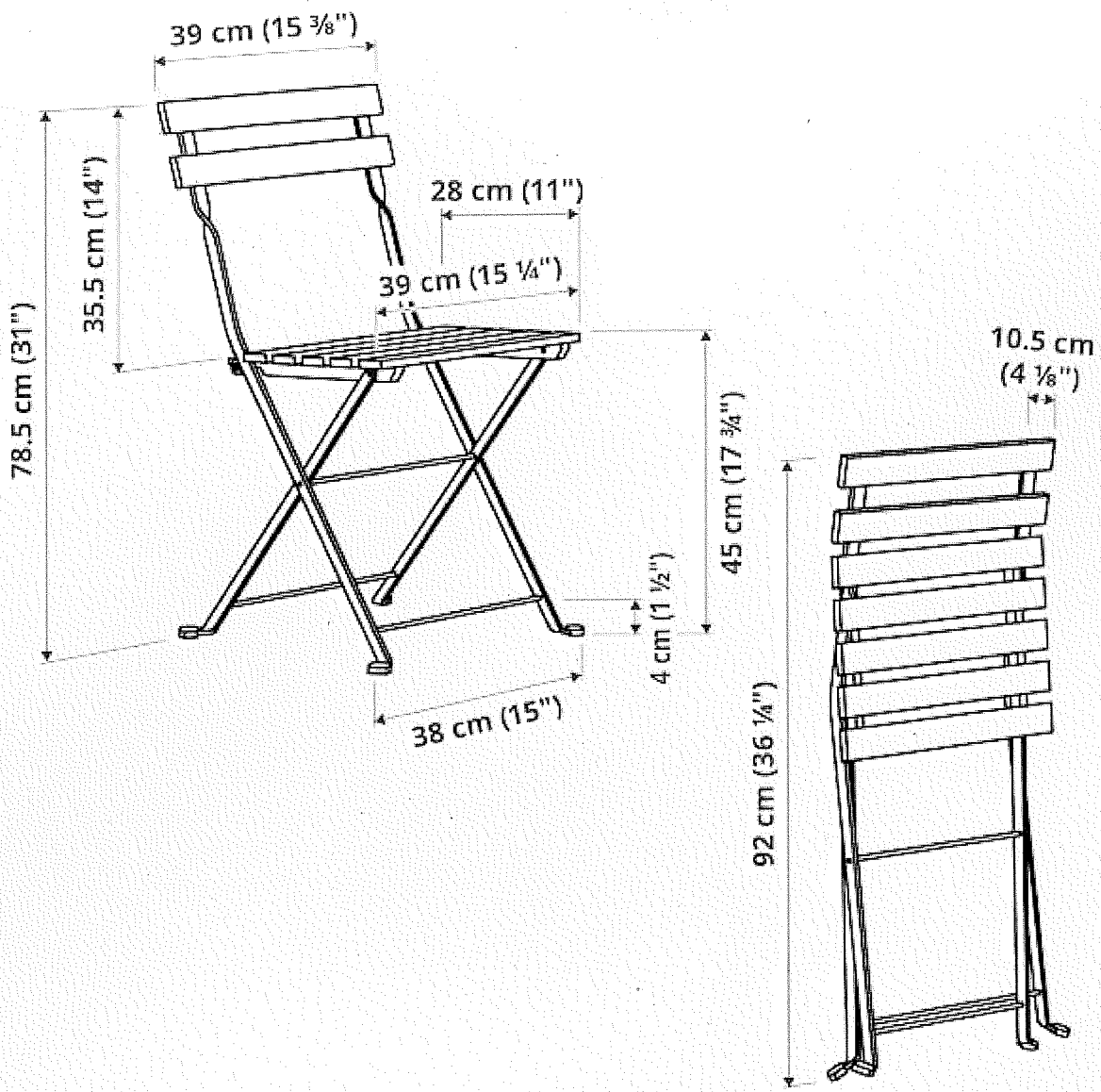



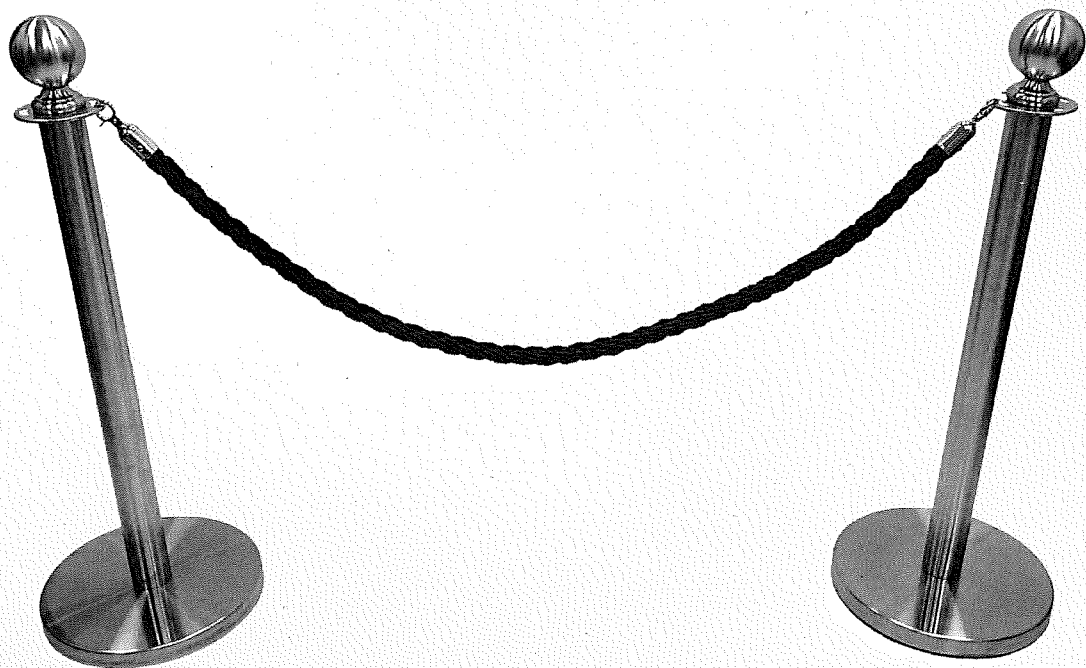

FROG ON THE BINE

